

TECHNICAL DATA SHEET

TOGGLE-AIRE®

Model 8500



MODEL:

TA8500

CATEGORY:

Pneumatic Toggle Press

OVERVIEW

Precise and Powerful

Joraco Press Company is proud to introduce the newest TOGGLE-AIRE® Series press to the family- the Model 8500! It features a substantial increase size and power, making it competitive with much larger, heavier hydraulic presses, but still operates on air alone. Larger than our benchtop units, but smaller than its competitors, the Model 8500 is a precise and powerful workhorse. The TOGGLE-AIRE® Series pneumatic toggle presses combine the mechanical advantages of levers and toggles; forces produced don't rely on ram impact, rather, it builds as the ram reaches the bottom of the stroke, and effects a shockless, powerful squeeze, regardless of ram speed.



PRODUCT FEATURES

Advantages and Benefits

01 Toggle substantially increases force relative to cylinder size and volume.

02 Included custom stand puts work area at ideal working height.

03 Operates with only an air line eliminating the need for costly rigging and wiring.

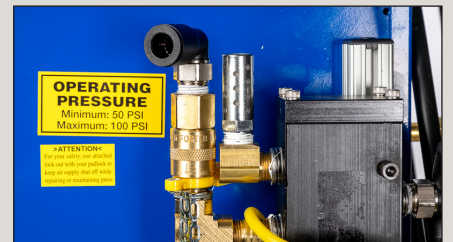
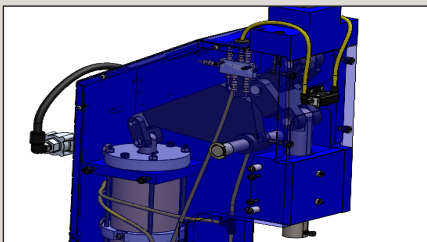

OPTIONS

- Roll Feed
- Rotary Indexing
- Riveting
- Force Monitoring
- Clean Room
- Heat Stamping
- PLC Automation
- Custom Tooling
- Die Sets

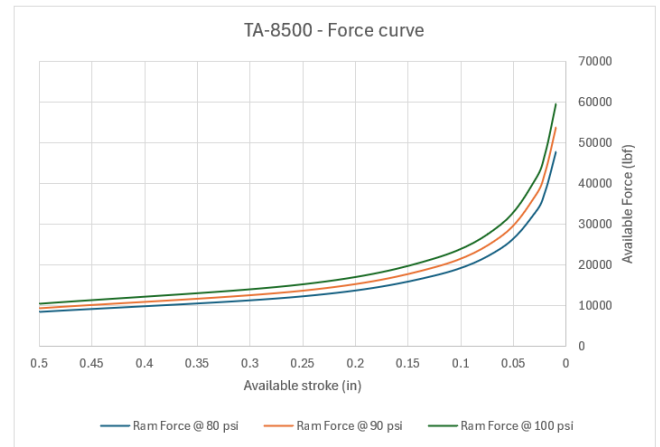
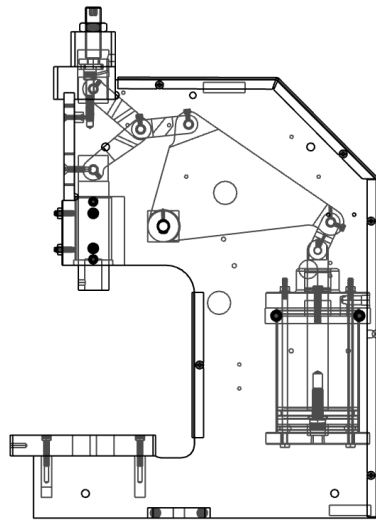

SPECIFICATIONS

Footprint Dimensions	33" W x 22.5" D	Shut Height	8" +/- 3/8"
Height w/Stand	64.5" +/-	Stroke	1.5"
Shipping Weight	1100 LBS	Throat	6"
Bolster Plate (Standard)	14" W x 10" D	Stroke	1.5"
Ram Diameter	2"	Ram Bore	3/4-10 x 1 1/2"

SAFETY STANDARDS

- ✓ **Robust, CNC Machined Quality**
Heavy-duty construction from cold-rolled steel and precision machine finishing provides a 5X or more safety factor above the forces generated by the cylinder.
- ✓ **OSHA Compliant Control**
100% pneumatic operation, including two hand, anti-tie down controller, valving, and maintenance lock out removes the need for electricity and an energized system.

OTHER CONTROL OPTIONS



SERVICE AND SUPPORT

Joraco Press Company offers comprehensive support for all our products. The benefit of being a direct sales brand is that the same engineers who designed your press are available to help troubleshoot your press. Also, you can now request service and order parts right on our website! There you will also find numerous articles, FAQs, downloads, and data to support your press operations.

CONTACT US!

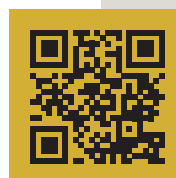

Address: 347 Farnum Pike.
Smithfield, RI 02917. USA
Phone: +1 401 232 1710
E-mail: sales@joraco.com

www.Joraco.com